

IC693MDL742

New In Stock!

GE Fanuc

<http://www.pdfsupply.com/automation/ge-fanuc/series-90-30/IC693MDL742>

Series 90-30

1-919-535-3180

In Stock! 12/24 Volts dc Output, 1 Amp, Positive Logic IC693M
IC693MD IC693MDL

www.pdfsupply.com

Email: sales@pdfsupply.com

12/24 Volt DC Positive Logic ESCP Output - 1 Amp, 16 Point IC693MDL742

The *12/24 volt DC Positive Logic 1 Amp Electronic Short Circuit Protection (ESCP) Output* module for the Series 90-30 PLC provides 16 output points in two groups of eight with a common power output terminal for each group. This output module is designed to have positive logic characteristics in that it sources current to the loads from the user common or positive power bus. The output device is connected between the negative power bus and the module output. The output characteristics are compatible with a wide range of user-supplied load devices, such as: motor starters, solenoids, and indicators. Power to operate the field devices must be supplied by the user.

LED indicators that provide the ON/OFF status of each point are located at the top of the module. This LED block has two horizontal rows with eight green LEDs in each row with the top row labeled A1 - A8 (points 1 through 8) and the bottom row labeled B1 - B8 (points 9 through 16). A red LED (labeled "F") on the right, centered between the two rows of green LEDs, functions as a tripped electronic short circuit protection indicator; it turns ON when any short circuit protection trip occurs. The common signal for each group is monitored electronically. If a short circuit occurs, the output points in the group turn off and the red LED turns on. The LEDs indicating output point status will not turn off. This protection does not protect individual outputs from exceeding their ratings, but will protect the board in case of a short circuited load. To reset electronic short circuit protection remove the 12/24 VDC user supply to the module. The module has two electronic short circuit protection circuits; each protects eight outputs - the first circuit protects A1 - A8, the second circuit protects B1 - B8.

An insert goes between the inside and outside surface of the hinged door. The surface towards the inside of the module (when the hinged door is closed) has circuit wiring information, and circuit identification information can be recorded on the outside surface. The outside left edge of the insert is color-coded blue to indicate a low-voltage module. There are no fuses on this module. This module can be installed in any I/O slot of a 5 or 10-slot baseplate in a Series 90-30 PLC system.

Table 7-14. Specifications for IC693MDL742

Rated Voltage	12/24 volts DC
Output Voltage Range	12 to 24 volts DC (+20%, -15%)
Outputs per Module	16 (two groups of eight outputs each)
Isolation	1500 volts between field side and logic side 500 volts between groups
Output Current †	1 amp maximum per point 4 amps maximum per group at @ 50°C 3 amps maximum per group @ 60°C
Output Characteristics	
Inrush Current	5.2 amps for 10 ms
Output Voltage Drop	1.2 volts maximum
Off-state Leakage	1 mA maximum
On Response Time	2 ms maximum
Off Response Time	2 ms maximum
Power Consumption	130 mA (all outputs on) from 5 volt bus on backplane

† Maximum load current is dependent upon ambient temperature as shown in graph on following page.

Refer to Appendix B for product standards and general specifications.

IC693MDL742 Output Module Field Wiring

The following figure provides wiring information for connecting user supplied load devices and power source to the 12/24 volt DC positive logic ESCP - 1 amp output module.

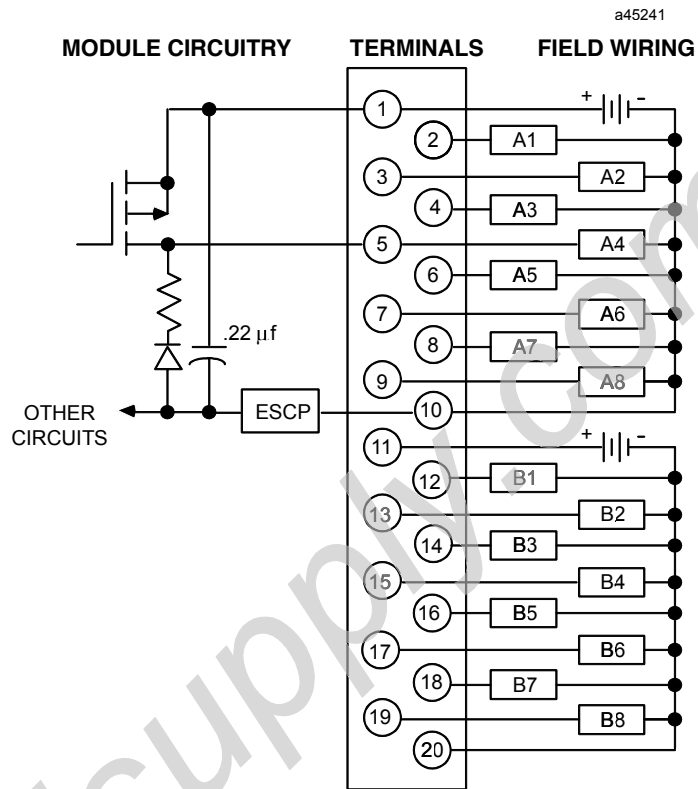

Figure 7-26. IC693MDL742 Output Module Field Wiring

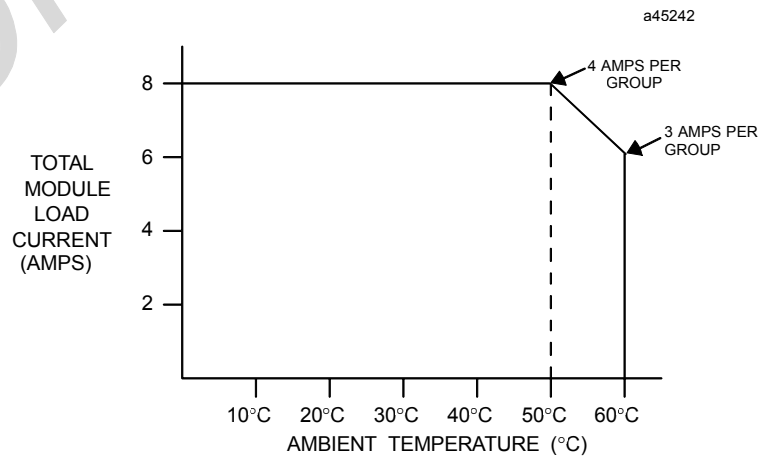

Figure 7-27. Load Current vs. Temperature for IC693MDL742